

AGREEMENT

This letter is to confirm that Mega Media acting as a Buying Service is authorized to purchase airtime and other media on our behalf and whereby we acknowledge our responsibility to provide payment in full to station per terms of their billing, Net Due upon receipt. Mega Media acting as a liaison will coordinate all buys and handle billings through their own internal systems, handling confirmations, affidavits, and payments through their own billings. This agreement further indemnifies Mega Media from personal liability for payment. Mega Media will provide payments to stations from broadcast billings and other vehicles such as print, billboard or other invoices billed to client as payments are received.

This agreement shall remain in effect until revoked by certified mail to said station or media entity.

Agreed to by: _____
Title: _____
Company: _____
Address: _____
City: _____ State: _____
Zip: _____ Phone: _____

Invoices and affidavits should be mailed to:

Client



Agency
7120 Harbor Landing
Alpharetta, GA 30005

602 • 421 • 8935

Date

Sincerely,

Dan L. Oliver

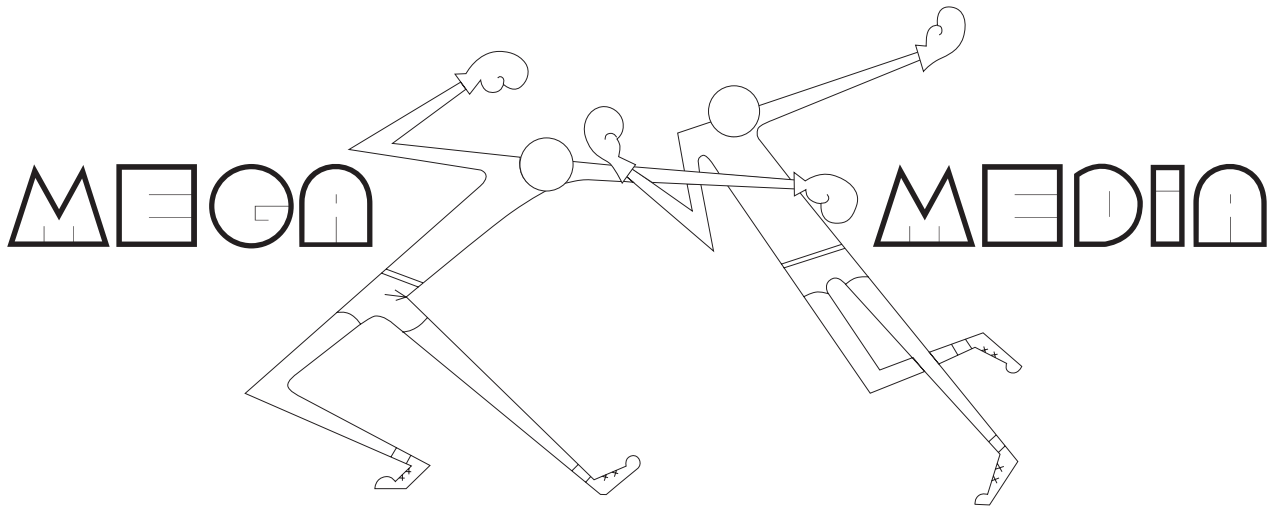

AGREEMENT

This contract is entered between Mega Media and _____
for the purpose of purchasing media in Television Cable Radio Print Outdoor Internet
 Other advertising.

As compensation _____ agrees that
compensation to Mega Media be gross billings from station invoices minus applicable agency
discounts as compensation. (gross amount due upon receipt.) Compensation is not construed as
direct payment, but rather a discount secured by Mega Media to be applied to the invoices received
as arranged by stated agency.

This agreement is entered on this: _____ day of: _____ 20____.

Dan L. Oliver
Media Director
Mega Media

Client

Authorization

Title

Address

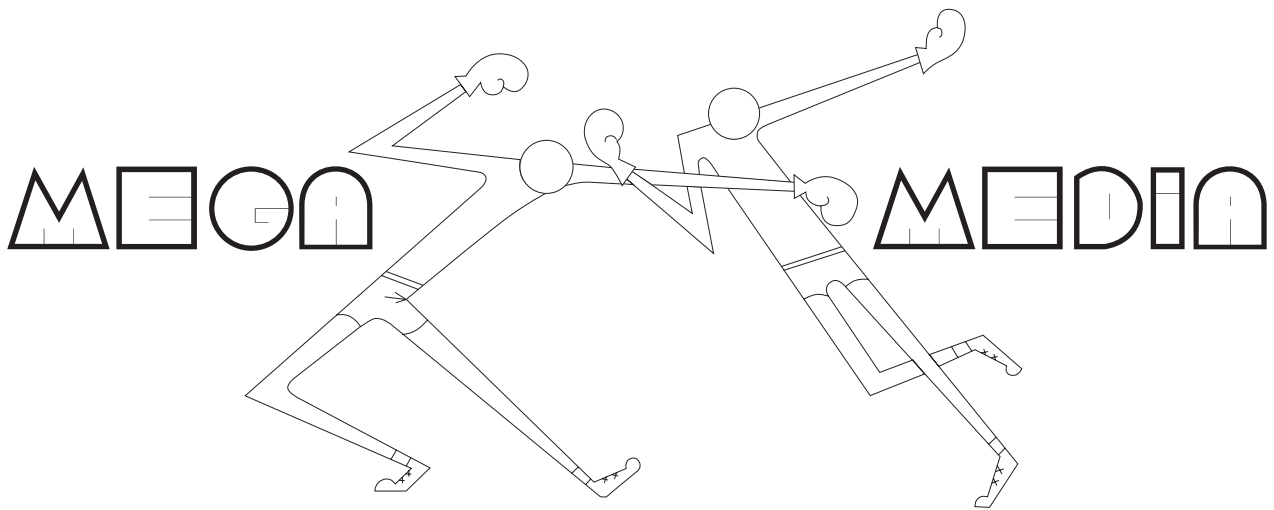

AGREEMENT

This contract is entered between Mega Media and _____
for the purpose of purchasing media in Television Cable Radio Print Outdoor Internet
 Other advertising.

As compensation _____ agrees to a
compensation to Mega Media in the form of a retainer in the amount of _____ Monthly.

Compensation is a direct payment, for services rendered for media buying, post analysis,
development of internal systems, creation of setting parity standards, creation of marketing and media
plans Value Per Impression and ROI analysis or other agreed to services based on client need.

This agreement is entered on this: _____ day of: _____ 20____.

Dan L. Oliver
Media Director
Mega Media

Client

Authorization

Title

Address

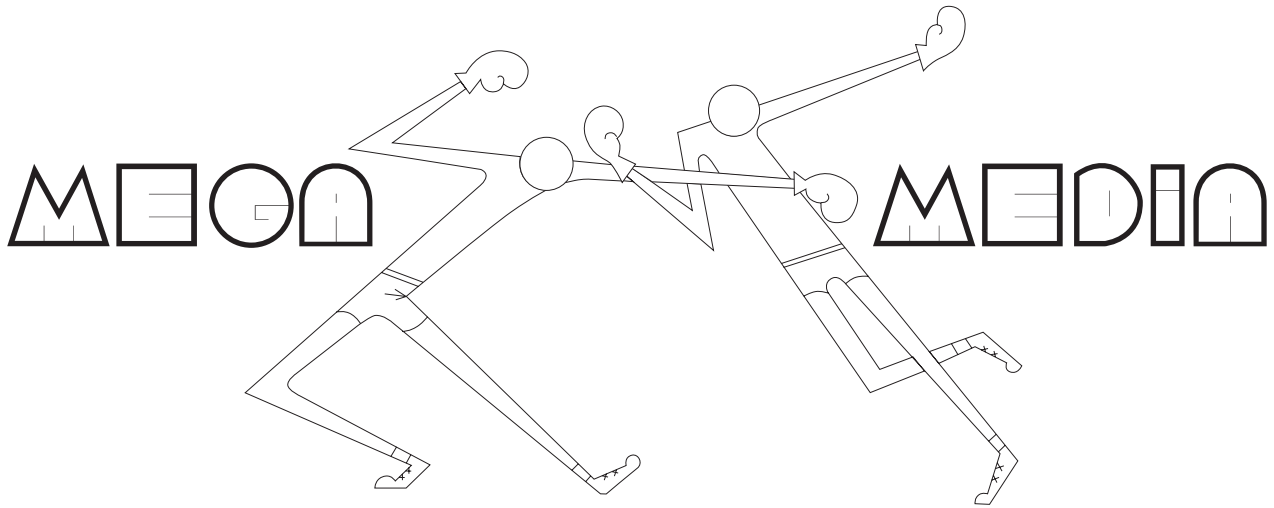

Credit Application to Media

Name: _____ Contact/Title: _____ Phone: _____
 City: _____ State: _____ Zip: _____
 President: _____ V.P. Finance: _____
 Corporation: _____ Partnership: _____ Proprietorship: _____
 Social Security or Tax ID Number If Corporation: _____
 Date Established: _____ Years at this address: _____
 Estimated Amount of First Contract: _____ Flight Dates: _____
 Have you ever declared bankruptcy in the past? Yes: _____ No: _____
 If you answered yes, please indicate date of filing: _____
 Name of Party responsible for payment: _____

Advertiser Information

Name: _____ Contact/Title: _____ Phone: _____
 Address: _____ State: _____ Zip: _____
 Corporation: _____ Partnership: _____ Proprietorship: _____

Advertising Media References

	Address	Contact	Phone
1. _____	_____	_____	_____
2. _____	_____	_____	_____
3. _____	_____	_____	_____

Bank Reference

Name	Address	Contact	Phone
1. _____	_____	_____	_____

Account Number: _____

Your signature authorizes any media outlet this is sent to the right to conduct a credit search concerning any information listed above. Your signature constitutes your acceptance and agreement to the following terms: Applicant is acting herein as advertiser. Notwithstanding any other provisions of the contract, the advertiser is ultimately severally liable for media payment. In the event of default hereunder, advertiser agrees to reasonable collection costs, costs of suit and reasonable attorney's fees incurred in enforcing this agreement. If payment is not made according to agreed payment terms, a late fee penalty equal to 18% per annum added to any unpaid invoices. The terms and conditions on this page and any attachments hereto are an integral part of this agreement unless specified in writing by and signed by an authorized party.

Authorized Signature: _____ Title: _____ Date: _____

For Internal Use Only

Account Executive: _____ Date: _____
 References Checked by: _____ Date: _____
 Approved By: _____ Date: _____
 Note: Special terms or other considerations: _____